

911 automatic antenna tuner

The GMDSS approved 911 automatic antenna tuner is designed for operation in both marine mobile and land base station installations.

Housed in a fully weatherproof enclosure the 911 will tune long wire antennas, wire loop antennas or whip antennas over a frequency range of 2 to 30MHz. Tuning is rapid, typically less than two seconds the first time RF is applied, either whilst the operator is talking or when the "Tune" control is activated on the transceiver.

The 911 tuner features a memory facility that stores the configuration required to tune to a frequency. On any subsequent use of that frequency the 911 reconfigures to the stored settings in typically 25 milliseconds. Following initial tuning the antennas VSWR is monitored. If any significant variation occurs the 911 will re-tune the antenna automatically.

The 911 is supplied complete with fully terminated control cables having an overall length of 6 metres. This comprises of a 1.5 metre stub cable with a 4.5 metre extension cable for connection to the transceiver. The cable is a composite design incorporating coaxial, power supply and control cables. Additional extension cables are available as required.

SPECIFICATIONS

Frequency range	2 to 30MHz
Channel capacity	Unlimited (Memory stores 10 FIFO).
Power rating	150 Watts PEP voice only
Power Requirements	12 Volts DC (nominal) 1 Amp (nominal)
Input impedance:	50 ohms, unbalanced
DC Isolation	Built-in
Dimensions	H350 X W285 X D75 mm Weight 3.5Kg



911 Automatic Antenna Tuner

911
911
911

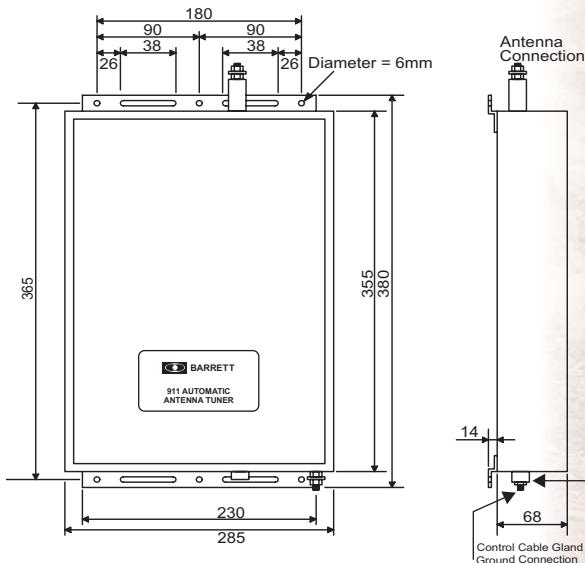



917 Marine Whip Antennas

The 917 series unloaded marine whip antennas are designed to operate in all marine bands from 2 to 30MHz.

Manufactured from heavy gauge aluminium tubing with a polymer coating or fibreglass with a rugged coating for marine and UV protection, they offer a large, low loss radiating surface. All fittings are manufactured from nylon, stainless steel and chromed bronze.

917 whip antennas are supplied in a range of sizes and mounting configurations to suit differing types and sizes of vessels.

BC91710: 3.6 metre marine swing down whip antenna

Is a 3.6 metre whip suitable for smaller vessels, particularly high speed craft. It is supplied complete with a stainless steel swing-down base fitting.

BC91711: 5.5 metre two piece marine side mount whip antenna

Is a 5.5 metre whip suitable for vessels over 10 metres in length. The whip is supplied in two sections which screw together on a self locking taper. Also included are side-mount insulators for mounting against a vertical structure.

BC91712: 8.0 metre high efficiency marine side mounted whip antenna

Is an 8.0 metre whip suitable for large vessels, the whip is supplied in two sections and is supplied complete with side-mount insulators for mounting against a vertical structure.

BC91713: 10 metre GMDSS high power whip

Is a 10 metre, GMDSS standard, base mounted whip suitable for large vessels. It is designed for professional use and can withstand wind speeds of up to 200Kph without permanent deformation.

SPECIFICATIONS

Frequency range	2 to 30MHz
Radiation Pattern	Omnidirectional
Polarisation	Vertical
Power Rating	BC91710 - 400 Watts BC91711 - 800 Watts BC91712 - 1000 Watts BC91713 - 1000 Watts

917 Marine Whip Antennas



Head Office:
Barrett Communications Pty Ltd P O Box 1214,
Bibra Lake WA 6965 AUSTRALIA
Toll Free Tel: 1800 999 580
Tel: (618) 9434 1700 Fax: (618) 9418 6757
email: information@barrettcommunications.com.au

European Office:
Barrett Europe Limited, Unit 9, Fulcrum 2,
Victory Park, Solent Way, Whiteley,
PO15 7FN UNITED KINGDOM
Tel: (44) 1420 542254 Fax: (44) 1420 543373
email: information@barretteurope.co.uk

Americas Office:
Barrett USA LLC 15941 W. 65th Street
Suite 373, Shawnee, Kansas 66217 USA
Tel: +1 913 322 6231 Fax +1 913 273 0779
email: information@barrettusa.com



MADE IN AUSTRALIA

